

Hellwig PRODUCTS.COM

559-734-7451 800-367-5480 FAX 559-734-7460

INSTALLATION INSTRUCTIONS

REAR STABILIZER BAR

97-07 G1500, SAVANA, EXPRESS VAN

Thank you for purchasing a quality Hellwig Product.

PLEASE READ THIS INSTRUCTION SHEET COMPLETELY BEFORE STA

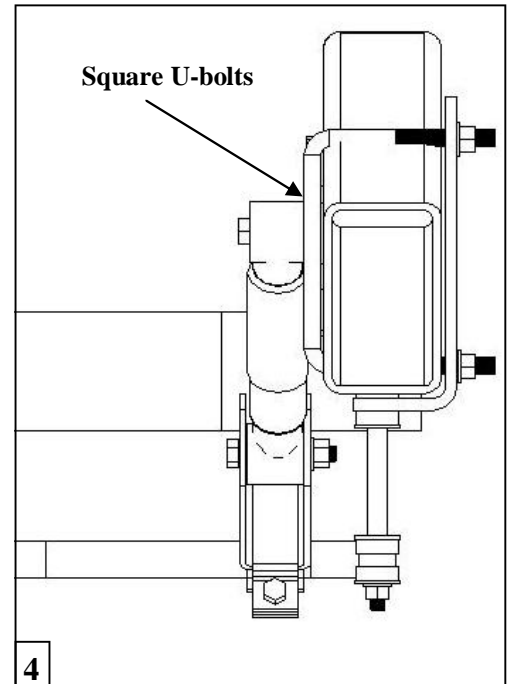
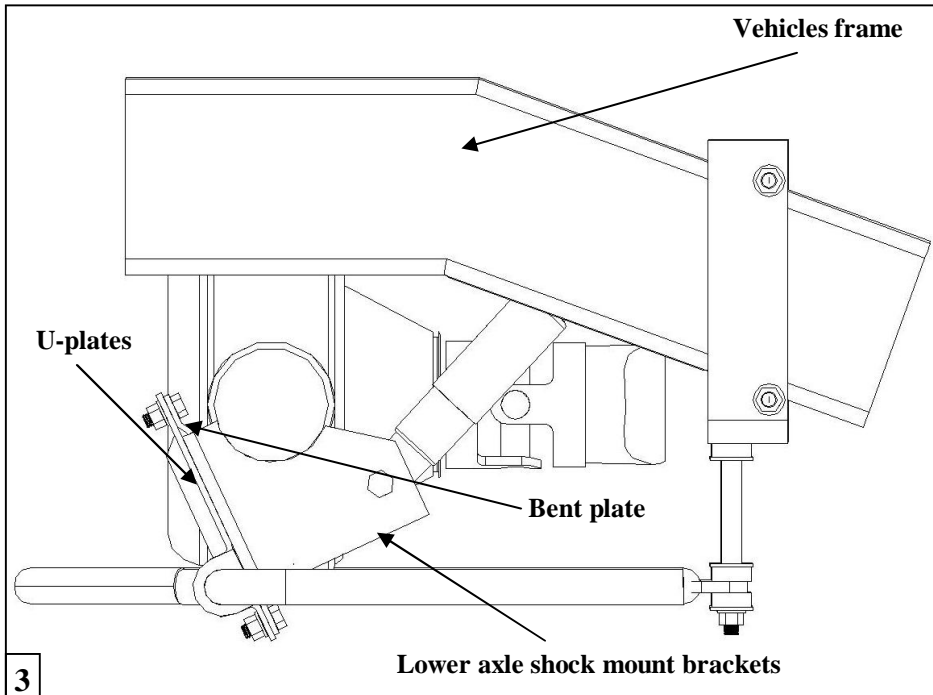
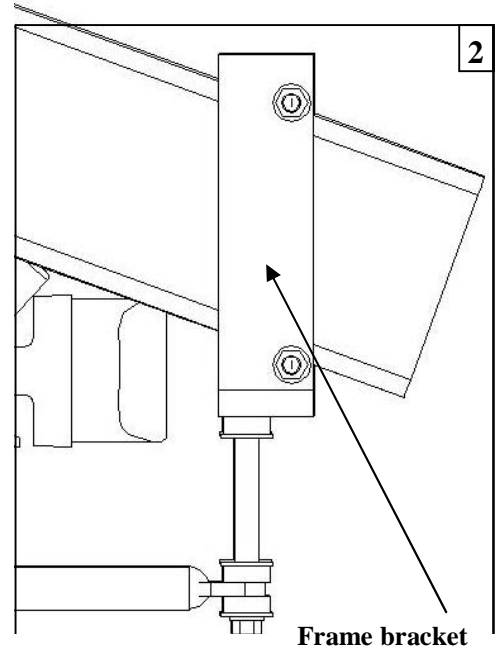
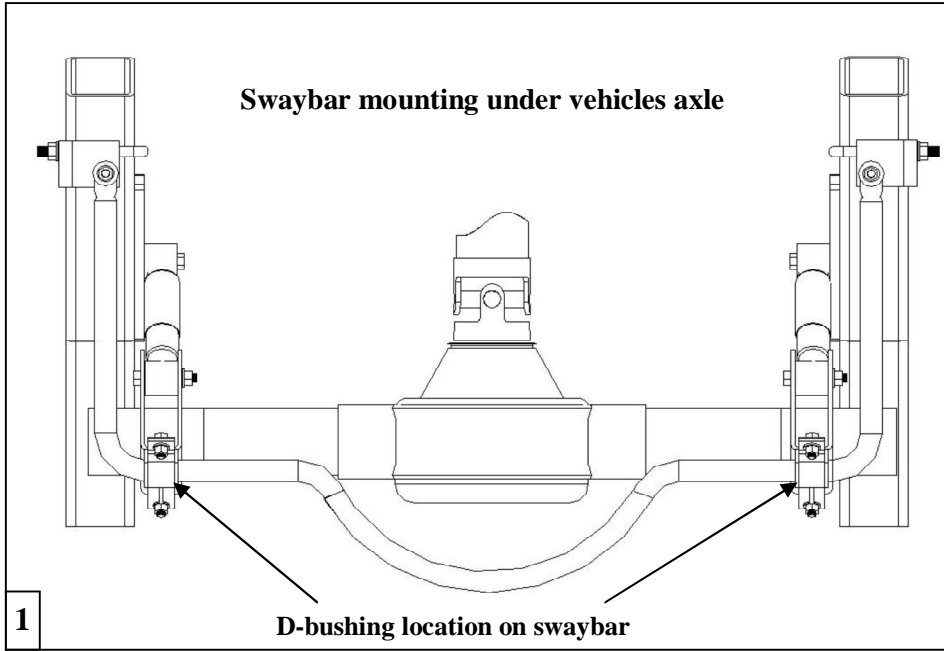

Hellwig PRODUCTS.com

559-734-7451 800-367-5480 FAX 559-734-7460

TORQUE TABLE

BOLT SIZE: 3/8" = 20-30 ft. lbs. – 7/16" = 35-45 ft. lbs. – 1/2" = 50-70 ft. lbs. – 9/16" = 70-90 ft. lbs. -5/8"=120 ft. lbs.

SAFETY: BEFORE STARTING YOUR INSTALLATION, BE SURE TO SET PARKING BRAKE AND CHOCK TIRES.

IMPORTANT: WHEN JACKING UP THE VEHICLE BE SURE THE VEHICLE IS SUPPORTED WITH JACK STANDS AND CANNOT FALL.

NOTE: THIS KIT INCLUDES LOCK NUTS WHICH REQUIRE TIGHTENING WITH A WRENCH AFTER BEING STARTED BY HAND.

NOTE: THIS SWAY BAR IS DESIGNED TO MOUNT TO THE REAR AXLE SHOCK MOUNT BRACKETS WITH THE SWAYBAR ARMS POINTING TOWARDS THE FRONT OF THE VEHICLE.

1. Place the D-shaped poly bushings on the flat areas of the sway bar on each side of the center hump. Align the D-bushings on the sway bar with the lower shock mount brackets that area welded to the rear axle assembly. **SEE PHOTO (1)**.
2. Place the U-plates over the D-bushings on the sway bar. Position the U-plates that the long ends of the U-plates point upwards. Insert the bent plates between the axle and the shock mount brackets. Attach the U-plates to the bent plates with hardware provided. The threads of the attaching bolts should be towards the rear of the vehicle. **LEAVE LOOSE AT THIS TIME TO ALLOW FOR ADJUSTMENT LATER. SEE PHOTO (3)**.
3. Assemble the end links assemblies and attach to the swaybar. As shown in photo (2). Tighten the lock nuts on the end links just slightly until the bushings start to bulge. Do not over tighten or damage to the bushings can occur. Attach the frame brackets to the end links assemblies. **NOTE: there is a left and a right frame bracket.**
4. Position the square U-bolts on the vehicles frame from the inside out. Be careful as not to damage or pinch any wires, brake or fuel lines on the vehicles frame. **SEE PHOTO (4)**.
5. Raise and rotate the sway bar up to the vehicles frame. Insert the square U-bolts through the holes on the frame brackets and attach with hardware provided. Tighten enough to support the swaybar, leave loose at this time to allow for adjustment later. Again check that there are no electrical wires, brake or fuel lines that will pinched or damages when tightening the mounting hardware to the U-bolts. The excess threads on the square U-bolts can be trimmed to avoid contact with the vehicles leaf spring assembly.
6. Center the swaybar on the axle, with the arms level with the ground and with the end links straight up and down as possible. Torque all mounting hardware to specified rates. .
7. Bounce the vehicle, check for clearance on all undercarriage components, exhaust, shocks, electrical wires, brake and fuel lines. Test drive the vehicle recheck your installation readjust as needed. Drive the vehicle for a week recheck installation readjust if needed. Check your installation on a monthly basis thereafter.

ATTENTION INSTALLER: BE SURE THAT THE CUSTOMER RECEIVES THIS INSTRUCTION SHEET, ALL IMORTANT NOTE CARDS AND THE WARRANTY FORM



16237 AVENUE 296 . VISALIA, CA 93292
TEL. (559) 734-7451 1-800-435-5977 FAX (559) 734-7460

PARTS LIST
RSB # 7623

PART #	QTY	DESCRIPTION
20217588	1	1-1/8" SWAY BAR
20907623	1	COMPLETION KIT
111000486	2	1-1/8" POLY BUSHING
20800845	2	U-PLATE
20800846	2	BENT PLATE
118000886	2	1/2" X 6-3/8" X 5-3/4" SQUARE U-BOLT
20800887	1	LEFT HAND FRAME BRACKET
20800889	1	RIGHT HAN D FRAME BRACKET
101500220	2	7/16" X 7" END LINK
125030336	1	BUSHING BAG # BG-336
111000389	8	END LINK BUSHING
125020233	1	SMALL PARTS BAG # BG-233
101500013	4	3/8" X 1-1/2" CAP SCREW
102306001	8	3/8" FLAT WASHER
102400023	8	7/16" FLAT WASHER
102520043	4	1/2" FLAT WASHER
107302003	4	3/8" LOCK NUT
107401042	2	7/16" LOCK NUT
107521044	4	1/2" LOCK NUT
20800221	2	1/2" X 3-1/4" END LINK SPACER
135007623	1	INSTRUCTION SHEET (R-7623)